

Installation Precautions:

- Basic performance of the lamp:
- Luminaire protection rating: IP65
- Degree of protection against electric shock: Class I
- Lamp input voltage: AC 220~240V

Installation Statement:

1. Please read the manual carefully before installation;
2. The installation of this lamp shall be carried out by personnel who meet the installation qualifications;
3. In order to avoid the risk of electric shock, please confirm to turn off the power before installation and maintenance;
4. The installation of lamps and lanterns shall comply with the corresponding local laws and regulations;
5. Suitable for indoor and outdoor installation and use;
6. Keep the manual for reference.

Lighting Installation:

Note: All installation and replacement or repair operations need to be cut off from the mains power!

Lamp Model:

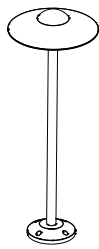

AEBA106*

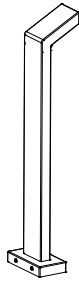

AEBA206*

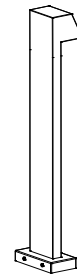

AEBA306*

Installing Luminaires:

1. AEBA106* installation method

1.1 The installation needs to be equipped with M5 stainless steel expansion bolts with the specifications and size requirements of the following figure (this bolt needs to be purchased by the customer).

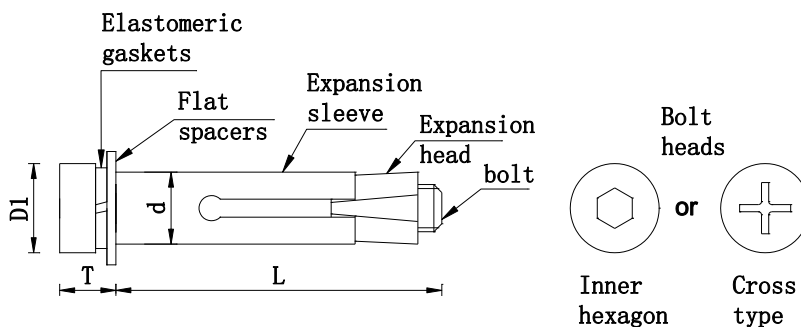

Bolt specification: M5 specification (hexagon or cross)
 Requirements: T (bolt head + spring pad + flat pad thickness) \leq 6.5mm
 L (bolt length) \geq 60mm
 D1 (bolt head diameter) $<$ ϕ 11

1.2 according to the position and size of the mounting hole of the installation chassis, drill the bottom hole on the foundation, Figure 1, Figure 2.

1.3 Connect the power cord with the mains according to the instructions of the fire/zero/ground wire label at the terminal of the power cord of the lamp, and the terminal shall be waterproof and anti-electric shock measures, Figure 3.

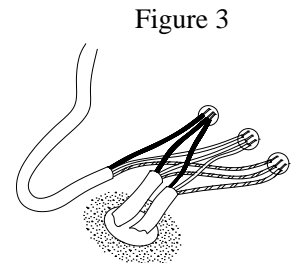
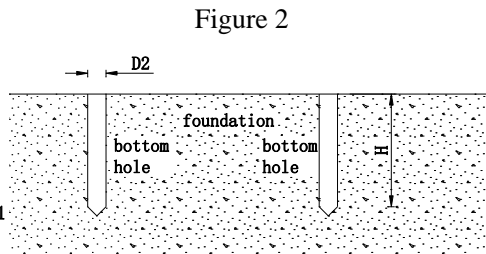
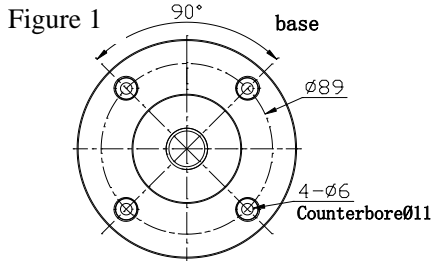

According to the size of the base mounting hole, the bottom hole is punched

The diameter of the bottom hole $D2 =$ the outer diameter of the expansion sleeve d
 Bottom hole depth $H \geq$ bolt length L
 M5 Specification $D = \phi 8\text{mm}$ (for reference)

The power cord is connected to the mains, and the connection end must be waterproof and anti-leakage

1.4 Install the expansion bolt on the base mounting hole, put it into the bottom hole, and the expansion sleeve is in a loose state. Then use an Allen wrench (or a cross-shaped screwdriver) to fix the lamp smoothly on the cement foundation, the expansion sleeve is in an expanded state, and the lamp installation is completed, Figure 4, Figure 5.

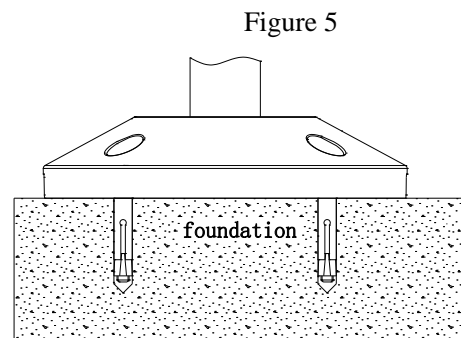
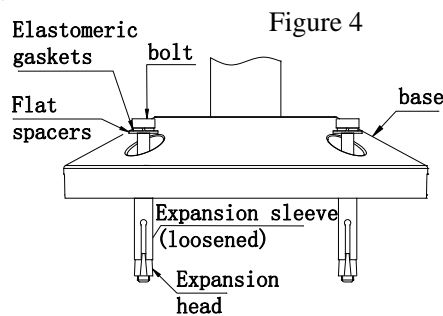

2. AEBA206*、AEBA306* Installation:

2.1 The installation needs to be equipped with M5 or M6 stainless steel expansion bolts (this bolt needs to be purchased by the customer).

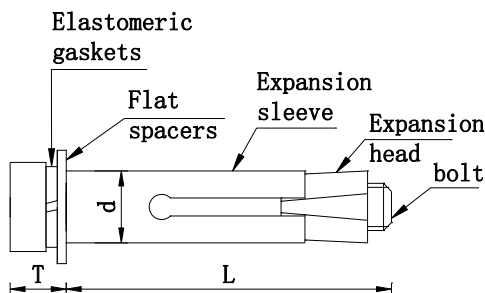

Bolt specifications: M5, M6 specifications
 Requirements: T (bolt head thickness + elastic pad thickness + flat pad thickness) $\leq 6.5\text{mm}$
 L (bolt length) $\geq 60\text{mm}$

2.2 Unpack and take out the lamp, loosen the fastening screws on both sides of the bottom of the lamp with an Allen wrench (2.5 specification), and take out the installation chassis, Figure 6 and Figure 7

Licensed by "WAC" trademark holder - WAC LIGHTING, USA
 Chinese Marketing Headquarters : WAC Lighting (Shanghai) Co, Ltd.
 Address : 14, Lane 299, Bi Sheng Road, Shanghai 201204, China
 China factory : Manufactured WAC Lighting (Dongguan) Co, Ltd.
 Address : 390, Qingfeng Road, Qingxi Town, Dngguan, Guangdong. Postal code: 523653

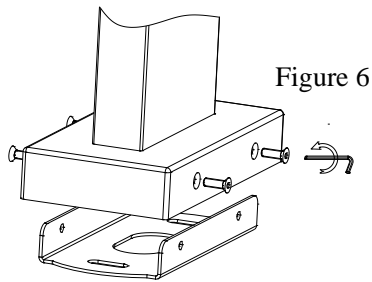

Figure 6

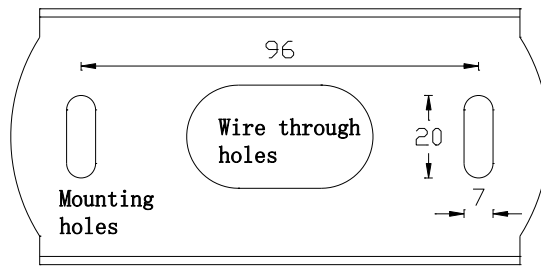

Figure 7

2.3 drill the bottom hole on the foundation according to the size of the mounting hole of the stainless steel chassis, Figure 7, Figure 8.

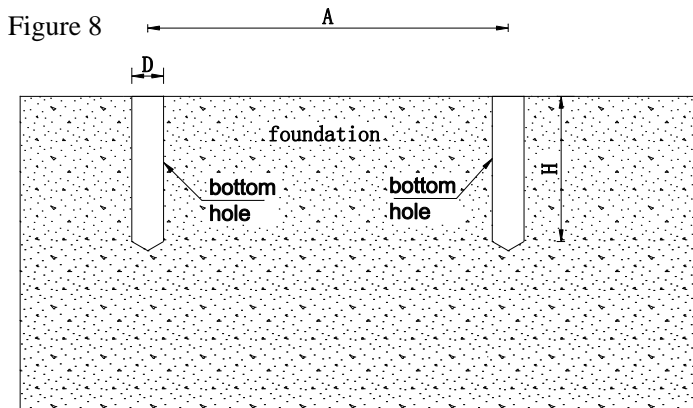

Figure 8

M5 and M6 stainless steel expansion bolts are selected
 Requirements: bolt length $L \geq 60\text{mm}$;
 Bottom hole depth $H \geq \text{bolt length } L$
 Bottom hole spacing $A=96\text{mm}$ (chassis mounting hole spacing size)
 Bottom hole diameter $D = \text{expansion sleeve outer diameter } d$
 M5 bolt bottom hole diameter $D=\varnothing 8\text{mm}$ (for reference)
 M6 bolt bottom hole diameter $D=\varnothing 10\text{mm}$ (for reference)

2.4 Install the stainless steel expansion bolt on the stainless steel chassis, and the expansion sleeve is in a loose state. Then the bolt is inserted into the bottom hole, and then the expansion bolt is locked with a hex wrench, and the chassis is smoothly fixed on the foundation, Figure 9.

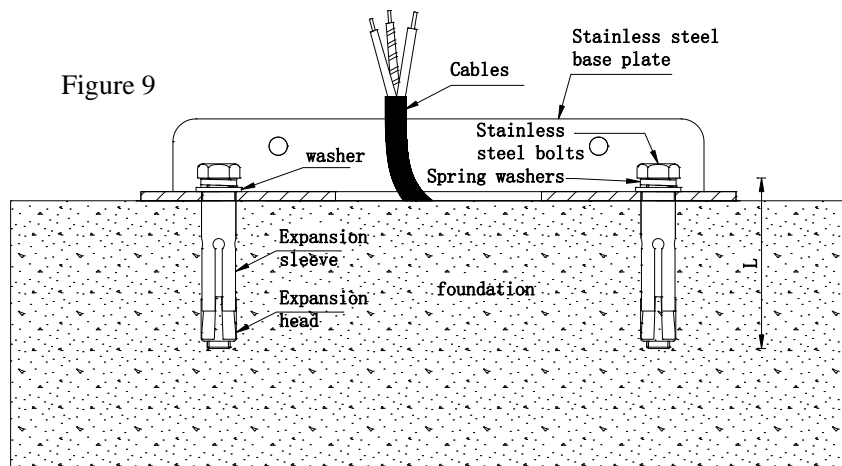

Figure 9

2.5 After the chassis is installed, according to the instructions of the power cord label of the lamp, connect the power cord with the mains, and do a good job of waterproof and anti-leakage measures, and then lock the lamp smoothly on the stainless steel chassis, and the installation of the lamp is completed, Figure 10, Figure 11, Figure 12.

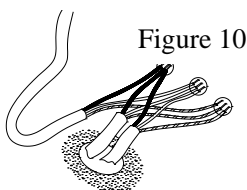

Figure 10

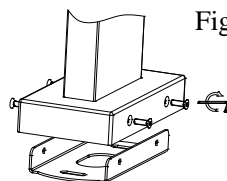

Figure 11

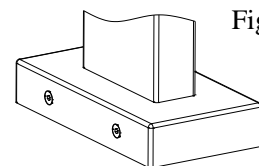

Figure 12

Replacement and repair of luminaires:

1. Turn off the power first, and wait for the lamp to cool down before operating;
2. The disassembly process is reversed from the installation sequence;
3. If the lamp fails, please contact the manufacturer's after-sales department as soon as possible to assist in dealing with it;
4. The replacement or repair process shall be operated by qualified personnel;
5. Do not disassemble the inside of the lamp without authorization.

Notes:

1. If the glass is found to be damaged during installation, it must be replaced; Please contact the manufacturer's after-sales department as soon as possible to assist in processing;
2. All wiring shall comply with the national installation specifications and standards, and the connecting joints between all wires shall be connected and waterproof and leakage-proof;
3. The external lead of the lamp cannot be replaced, if the lead is damaged, the lamp will be destroyed, and the replacement of the wire must comply with the CCC standard;
4. And require qualified personnel to replace and connect to avoid danger;
If the external cable of the luminaire is damaged, the cable shall be replaced and connected by the manufacturer or a similarly qualified person;
5. Do not disassemble the inside of the lamp without authorization;
6. The light source of this luminaire is irreplaceable; When the light source reaches the end of its life, the entire luminaire should be replaced;
7. The terminal of the power cord of the lamp and lantern needs to be waterproof and anti-leakage measures to prevent safety accidents;
8. The lamp is not equipped with installation accessories, and the customer needs to consider the firmness and reliability of the lamp installation when installing the lamp, and then purchase the installation accessories according to the need.