

Installation Precautions:

1. Please read through the Instructions before installation.
2. The product should be installed by a professional electrician.
3. Make sure the power supply is cut off before installation and maintenance, to avoid the risk of electric shock.
4. The installation of lighting fixtures must comply with the corresponding local laws and regulations
5. Suitable for indoor and outdoor installation and use.
6. Keep the instruction manual for reference only.

Light Installation:

1. Installation of lighting fixtures
 - A: Open the packaging, take out the lamp, loosen the fastening screws on the side of the base with an Allen wrench (2.5mm), take out the installation chassis, drill $\varnothing 8$ holes on the installation surface, with a center distance of $L=35 \pm 2\text{mm}$. After fixing the M6 expansion bolt, place the chassis, and then use a tool to lock the nut (as shown in Figure 1 A);

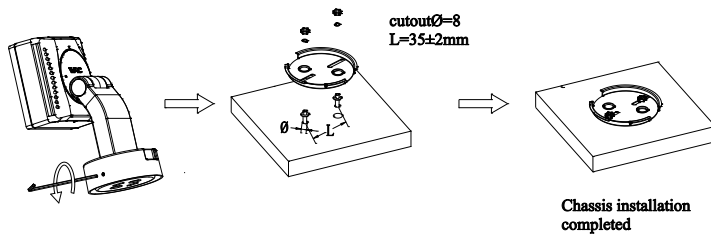

Figure 1:A

- B: The installation method of EF3N01 is as follows (as shown in Figure 1 B); Drill suitable installation holes on the ground, install geckos, fix the lighting fixtures with screws (purchased by the customer), adjust the lighting fixtures, loosen the fixing screws of the lighting fixtures with an Allen wrench (2.5mm), adjust to the desired angle (the horizontal direction of the lighting fixtures can be adjusted), and fix the screws;

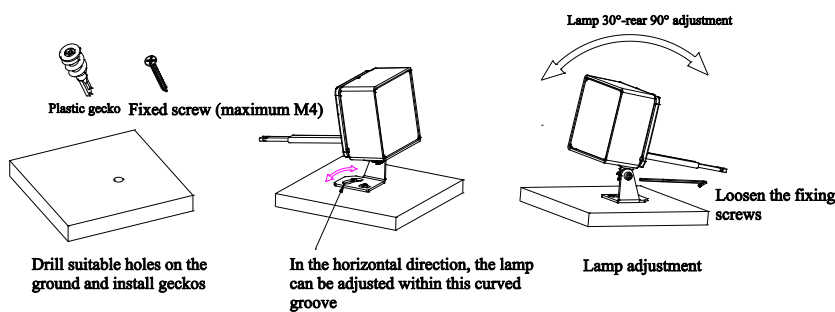

Figure 1:B

2. Thread the light fixture cable out of the wire hole on the installation chassis or through the side of the light fixture base, adjust the base to match the gap on the installation chassis, match the two, tighten the base clockwise, and then use an Allen wrench (2.5mm) to lock the side fastening screws (as shown in Figure 2);

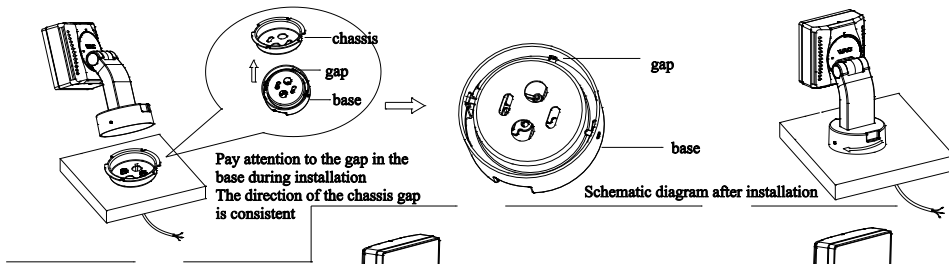
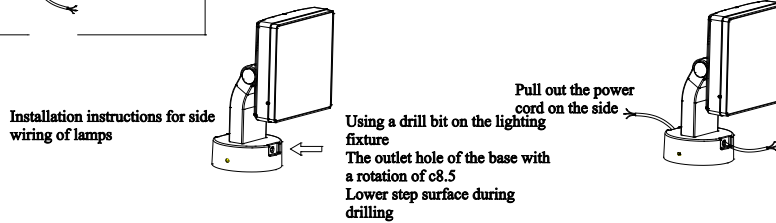

Figure 2



- Lamp angle adjustment: Loosen the fixing seat screw (tool 1.58mm hex wrench), the lamp can be adjusted horizontally from 0 ° to 330 ° (clockwise), loosen the fixing screw on the bracket (tool 1.58mm hex wrench), and the lamp can be adjusted back and forth from 30 ° to 150 ° (see Figure 3);

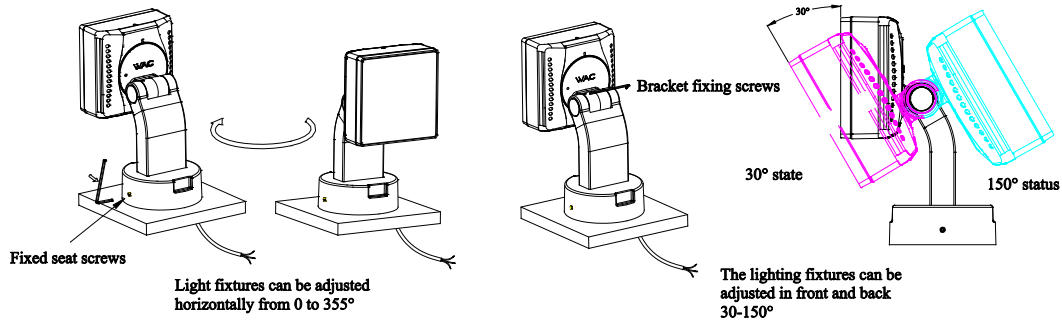

Figure 3

- The lamp body can be adjusted horizontally from 0 ° to 90 ° (counterclockwise). Loosen the fixing screws on the lamp body, adjust the lamp body counterclockwise, and adjust the angle horizontally from 0 ° to 90 °. After adjustment, tighten the fixing screws (as shown in Figure 4);

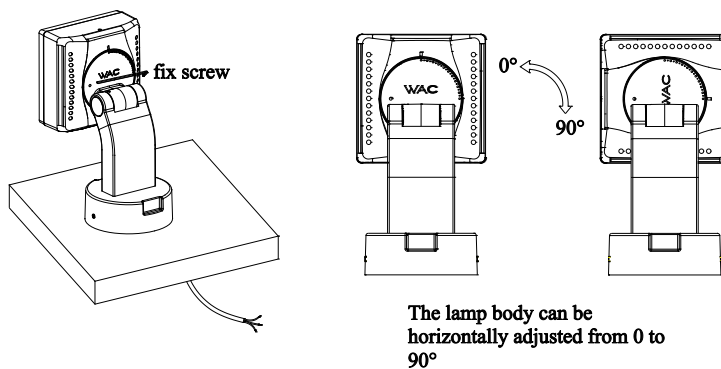

Figure 4

- Light fixture wiring, different versions of wiring are shown in the figure below, and waterproof treatment should be done at the wiring points.

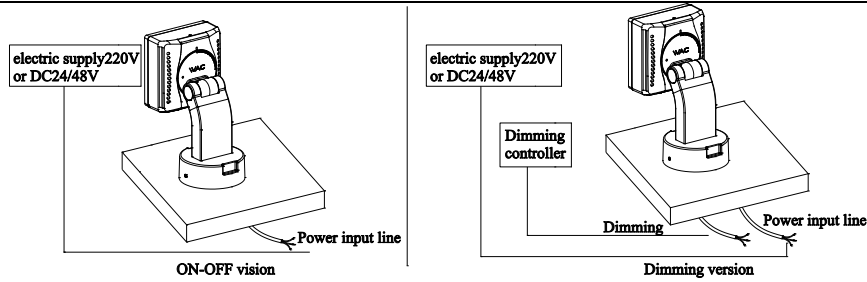
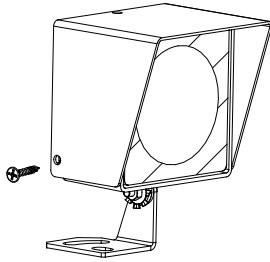

Figure 5



6. Installation of anti glare accessories for lighting fixtures (customer to purchase separately if necessary), fix the anti glare accessories to the lamp body with screws (see Figure 5).

Replacing and repairing lighting fixtures:

Turn off the power first and wait for the lighting fixtures to cool down before operating. The disassembly process is the opposite of the installation sequence, and both replacement and maintenance processes require professional operation.

Note:

1. The cable is not included and uses a waterproof 3-core cable with a diameter of $\varnothing 5$ - $\varnothing 9$ mm (marked on the connector: live wire L; neutral wire N; ground wire);

Notes:

1. If damage is found to the glass protective cover during installation, it must be replaced;
2. When the glass protective cover is damaged and replaced, customers can only use the glass protection provided by our company.